

⚠ WARNING: PHOTOSENSITIVITY/EPILEPSY/SEIZURES

A very small percentage of individuals may experience epileptic seizures or blackouts when exposed to certain light patterns or flashing lights. Exposure to certain patterns or backgrounds on a television screen or when playing video games may trigger epileptic seizures or blackouts in these individuals. These conditions may trigger previously undetected epileptic symptoms or seizures in persons who have no history of prior seizures or epilepsy. If you, or anyone in your family, has an epileptic condition or has had seizures of any kind, consult your physician before playing. IMMEDIATELY DISCONTINUE use and consult your physician before resuming gameplay if you or your child experience any of the following health problems or symptoms:

- ▶ dizziness
- ▶ eye or muscle twitches
- ▶ disorientation
- ▶ any involuntary movement
- ▶ altered vision
- ▶ loss of awareness
- ▶ seizures
- ▶ or convulsion.

RESUME GAMEPLAY ONLY ON APPROVAL OF YOUR PHYSICIAN.

USE AND HANDLING OF VIDEO GAMES TO REDUCE THE LIKELIHOOD OF A SEIZURE

- ▶ Use in a well-lit area and keep as far away as possible from the television screen.
- ▶ Avoid large screen televisions. Use the smallest television screen available.
- ▶ Avoid prolonged use of the PlayStation®3 system. Take a 15-minute break during each hour of play.
- ▶ Avoid playing when you are tired or need sleep.

Stop using the system immediately if you experience any of the following symptoms: lightheadedness, nausea, or a sensation similar to motion sickness; discomfort or pain in the eyes, ears, hands, arms, or any other part of the body. If the condition persists, consult a doctor.

NOTICE:

Use caution when using the DUALSHOCK®3 wireless controller motion sensor function. When using the DUALSHOCK®3 wireless controller motion sensor function, be cautious of the following points. If the controller hits a person or object, this may cause accidental injury or damage. Before using, check that there is plenty of space around you. When using the controller, grip it firmly to make sure it cannot slip out of your hand. If using a controller that is connected to the PS3™ system with a USB cable, make sure there is enough space for the cable so that the cable will not hit a person or object. Also, take care to avoid pulling the cable out of the PS3™ system while using the controller.

WARNING TO OWNERS OF PROJECTION TELEVISIONS:

Do not connect your PS3™ system to a projection TV without first consulting the user manual for your projection TV, unless it is of the LCD type. Otherwise, it may permanently damage your TV screen.

HANDLING YOUR PS3™ FORMAT DISC:

- ▶ Do not bend it, crush it or submerge it in liquids.
- ▶ Do not leave it in direct sunlight or near a radiator or other source of heat.
- ▶ Be sure to take an occasional rest break during extended play.
- ▶ Keep this disc clean. Always hold the disc by the edges and keep it in its protective case when not in use. Clean the disc with a lint-free, soft, dry cloth, wiping in straight lines from center to outer edge. Never use solvents or abrasive cleaners.

CONTENTS

2	GETTING STARTED
2	INTRODUCTION
3	STARTING TO ROCK
3	COMPLETE CONTROLS
8	OPTIONS
8	TV CALIBRATION
10	LEARNING TO ROCK
10	TRAINING
11	GUITARIST/BASSIST
12	PRO GUITARIST
13	DRUMMER
14	PRO DRUMMER
14	KEYBOARD
15	PRO KEYS
15	SINGERS
16	ENERGY
18	BIG ROCK ENDINGS
18	PERSONAL MENU
18	QUICKPLAY
20	NEW ROAD CHALLENGE
20	NEW SPADES METER
20	CAREER
21	CUSTOMIZE
21	CUSTOMIZE BAND
21	CUSTOMIZE CHARACTER
22	CREATE CHARACTER
22	PLAY ONLINE
23	ROCK BAND MUSIC STORE
23	DISC EXPORT
25	CREDITS
25	SONGS
33	LIMITED 90-DAY SOFTWARE WARRANTY

This product has been rated by the Entertainment Software Rating Board. For information about the ESRB rating please visit www.esrb.org.

GETTING STARTED

PLAYSTATION®3 SYSTEM

Starting a game: Before use, carefully read the instructions supplied with the PS3™ computer entertainment system. The documentation contains information on setting up and using your system as well as important safety information.

Check that the MAIN POWER switch (located on the system rear) is turned on. Insert the *Rock Band*® 3 disc with the label facing up into the disc slot. Select the icon for the software title under [Game] in the PS3™ system's home menu, and then press the **X** button. Refer to this manual for information on using the software.

Quitting a game: During gameplay, press and hold down the PS button on the wireless controller for at least 2 seconds. Then select "Quit Game" from the screen that is displayed.

HINT: To remove a disc, touch the eject button after quitting the game.

Saved data for PS3™ format software

Saved data for PS3™ format software is saved on the system's hard disk. The data is displayed under "Saved Game Utility" in the Game menu.

INTRODUCTION

The world's greatest music experience is more epic than ever before! Take your band to professional status with *Rock Band*® 3, featuring new modes, new gameplay, and Pro instruments!

In addition to tons of new music, *Rock Band*® 3 features:

- ▶ All Instruments mode—Play with up to seven members in your band! That's some stage presence.
- ▶ New Road Challenge mode—Begin the road trip of a lifetime as your 1-7 player band performs a set-list of songs and challenges.
- ▶ Rock Band Pro—An all new way to play *Rock Band* that teaches you skills for playing a real instrument!
- ▶ New Keys—The addition of a keyboard and Pro Keys are perfect for rounding out your ideal band.

In addition to all of the new modes and experiences, there are even more exciting new features in *Rock Band*® 3:

- ▶ Most songs from other *Rock Band* titles and the Rock Band Music Store can be exported to *Rock Band*® 3 without any re-downloading.
- ▶ Instantly switch between your characters from your personal menu.
- ▶ Auto-calibrate your game with the wireless Pro Guitars and Drums, or try the calibration chart (p. 9) for suggestions on how to get the ideal setup.
- ▶ Personal menu—Each player can access their own personal menu to access the PlayStation®Network, characters, options, and more.

STARTING TO ROCK

COMPLETE CONTROLS

MENU NAVIGATION

NOTE: If you have no instrument connected and your microphone does not have built-in control buttons, you must also have a PlayStation®3 controller connected in order to navigate the menus and set up the game.

To navigate menus, move the left stick or the directional button to highlight an option, press the **X** button to open its submenu (if applicable), press the directional button or move the left stick again to highlight a selection, then press the **X** button to confirm.

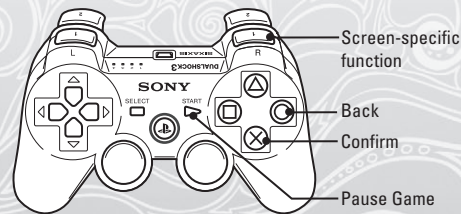

www.rockband.com
www.facebook.com/RockBand
www.twitter.com/RockBand

VOCALS

Adjust vocal track volume (when microphone is enabled)

Adjust the volume of your vocals (when microphone is enabled)

Adjust mic sensitivity (when microphone is enabled)

Pause game

⓪ button

Ⓜ button

Ⓛ button

START button

WIRELESS FENDER™ STRATOCASTER™ GUITAR CONTROLLER (SOLD SEPARATELY)

To play guitar or bass, press and hold the fret buttons matching the notes you see coming down the track. When those notes cross the target at the bottom of the screen, hit the strum bar to play the note.

- ▶ Don't forget, you can hold those fret buttons down in advance. Just like with a real guitar, it only makes noise if you strum.

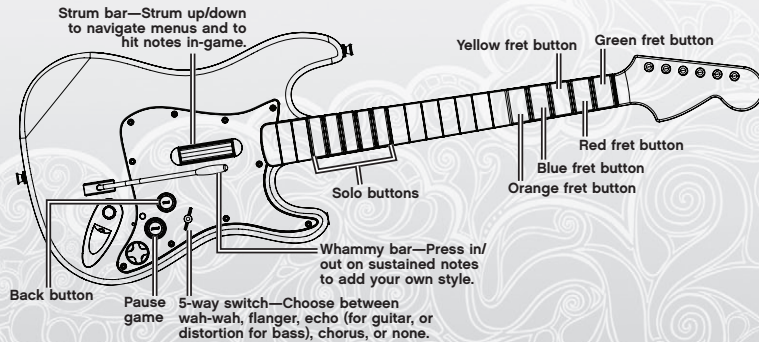

NOTE: Tilt the controller neck upwards to go into Overdrive.

- ▶ For information on how to play the guitar in-game, see p. 11.

PRO GUITAR CONTROLLER (SOLD SEPARATELY)

To play professional level guitar, use the Wireless Fender™ Mustang™ PRO-GUITAR™ Controller. Pro Guitars play like a real six-string guitar. Numbered notes will come down the track and the number tells you what fret to press. Use your fretting hand to press down just behind the fret on the string the note is on. When the note crosses the bar on the bottom of the track, use your strumming hand to play the string. Notes and chords can show up on any of the six strings.

- ▶ The position wave helps you keep track of your fretting fingers' locations. This is really helpful when playing chords.

NOTE: To enable Pro Guitar mode, you must be playing with one of the Pro Guitar controllers.

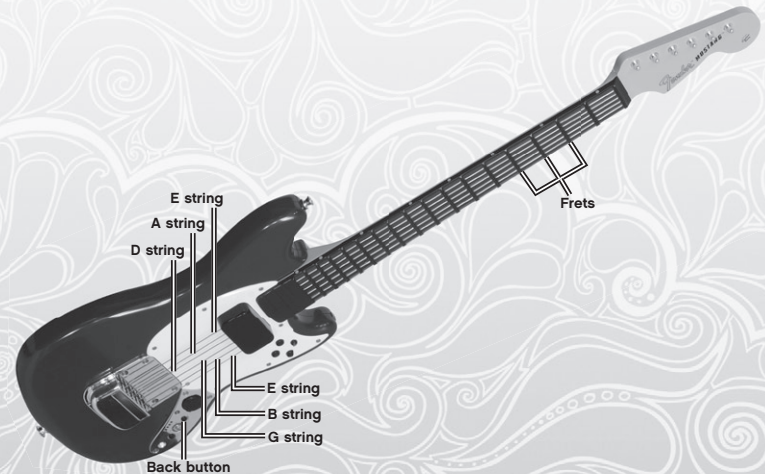

NOTE: Tilt the controller neck upwards to go into Overdrive.

- ▶ For information on how to play the Pro Guitar in-game, see p. 12.

DRUMS AND PRO DRUMS (SOLD SEPARATELY)

To play drums or Pro Drums, use your drumsticks to hit the pads that match the rhythm notes as they cross the target at the bottom of the track. Press your foot down on the kick pedal when you see wide, orange notes cross the target at the bottom of the track.

To enable Pro Drums, attach the Rock Band Cymbals (not shown - sold separately) and then go to the Options menu, select DRUM OPTIONS, and then enable Pro Drums.

NOTE: You must have at least one of the Rock Band Cymbals attached to enable Pro Drums. However, to achieve the ultimate drum solo, you will definitely want to attach all three Rock Band Cymbals.

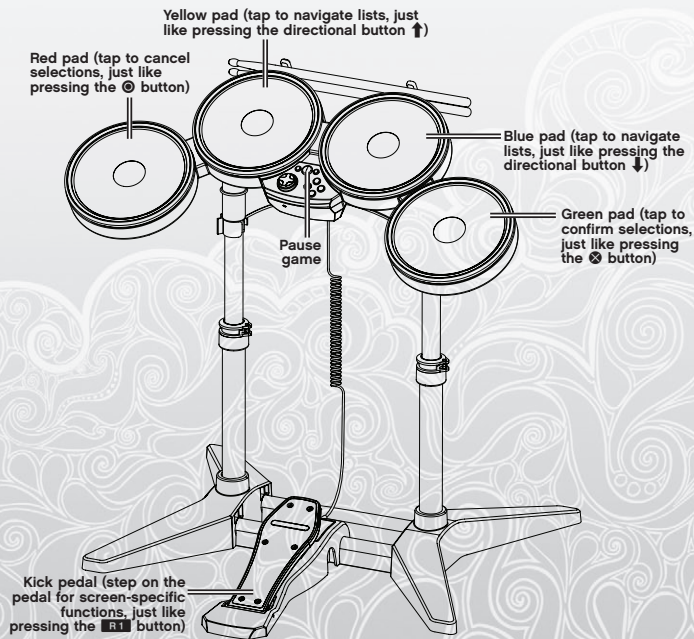

IMPORTANT NOTE: If you run out of USB ports while connecting Rock Band USB-compatible peripherals, you can use any USB hub for additional ports.

WIRELESS KEYBOARD (MAY BE SOLD SEPARATELY)

The Wireless Keyboard Controller is brand new to Rock Band® 3. Each of the five white keys from the C key to the G key, are used. The keys are displayed on the track, just like they are for guitar or bass. There's a handy guide on the keyboard to show you where the keys are if you're not an experienced musician.

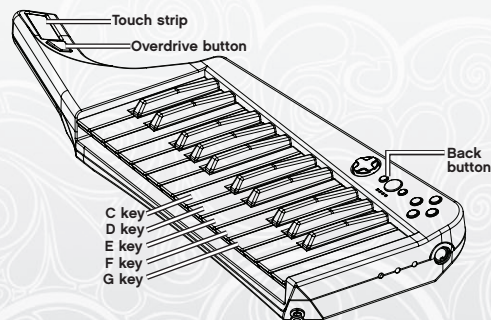

PRO KEYS

Pro Keys are played with the same Wireless Keyboard controller and allow you to play pitch accurate keyboard parts in Rock Band® 3. When playing the Pro Keys, 10 white keys are always shown onscreen. Press the corresponding key when it reaches the base of the track. Whenever a key is pushed down, the key lane will light up. This helps you keep your eyes on the screen and not on the Pro Keys controller.

OPTIONS

To adjust options, select **OPTIONS** from your personal menu.

- ▶ Select **ALL INSTRUMENTS MODE** to allow a guitarist, drummer, bassist, keyboardist, and three vocalists to all play at once.
- ▶ Select instrument-specific options to customize your chosen instrument.
- ▶ Select **SYSTEM SETTINGS** to adjust your audio, screen, calibration, and autosave settings.
- ▶ Select **EXTRAS** to view the *Rock Band*® 3 credits and link your account with rockband.com. To link your account, make sure you are signed into a profile and then select **ACCOUNT-LINKING CODE** to be given a code that you can use at www.rockband.com. Additional Terms and Conditions apply.
- ▶ Select **MODIFIERS** to unlock special content – created especially for the true *Rock Band* aficionado.

TV CALIBRATION

Even the most novice musician should be able to pick up and play *Rock Band*® 3 right out of the box. In some cases, however, particularly with HDTV systems, the audio and video may play at different times, making it difficult to play the right note at the right time. If you are ready to blame your TV for your less-than-stellar musicianship, try calibrating your system.

To calibrate your system, select **CALIBRATION** from the Console Settings in the Options menu. If you have a *Rock Band*® 3 Wireless Fender™ Stratocaster™ Guitar Controller, select **CALIBRATE AUTOMATICALLY**. If you don't, or if you would prefer to calibrate manually, select **CALIBRATE MANUALLY**. You can also select **ENTER CALIBRATION NUMBERS** to manually set the audio latency compensation by pressing the directional buttons → or ←.

AUTO CALIBRATION

- ▶ To calibrate your system's audio timing, when you are prompted, hold your *Rock Band*® 3 Wireless Fender™ Stratocaster™ Guitar Controller or Wireless Fender™ Mustang™ PRO-GUITAR™ Controller up to your sound system speaker or your TV's speaker (wherever the sound is coming from) as close as possible without touching. The volume should be set to a comfortable listening volume. If you have trouble in a room with a surround system, turning the volume down sometimes helps. Hold your guitar controller there until prompted.

- ▶ To calibrate your system's video timing, when you are prompted, hold your *Rock Band*® 3 Wireless Fender™ Stratocaster™ Guitar Controller up to the center of your TV screen, with the guitar controller facing the TV and as close to the TV as possible without touching. This tends to work best in darker rooms, so either turn the lights down or angle the guitar slightly downwards away from the light. Hold your guitar controller there until prompted.
- ▶ You should now be ideally calibrated! Test out a song in Quickplay to make sure it feels right. If not, try auto-calibrating again, or try calibrating manually.

MANUAL CALIBRATION

1. Select **OPTIONS** from the main menu, then **SYSTEM SETTINGS**, then **CALIBRATION**, and finally **CALIBRATE MANUALLY**.
2. Each time you hear a drum beat, press the ⊗ button/strum/hit the green pad in time with the beat you hear.
3. Proceed to Step 2: **VIDEO CALIBRATION**. When you see the needle hit either side of the meter, press the ⊗ button/strum/hit the green pad in time with the needle.
4. Press the ⊗ button. Your system is now calibrated. Test it out!

MANUALLY SET NUMBERS

If you can't get an ideal calibration using auto calibration or manual calibration, try setting your calibration numbers by hand. Select **ENTER CALIBRATION NUMBERS** from the Calibration menu and check out the chart below. These numbers can be a useful starting point to help you find the best settings for your television type. Try starting with the numbers below and adjust gradually as needed until the settings feel just right.

LCD 1	Audio 80, Video 50
LCD 2	Audio 15, Video 30
CRT	Audio 0, Video 0
DLP	Audio 15, Video 60
Rear-Projection	Audio 5, Video 50
Plasma	Audio 50, Video 50

- ▶ Once you've gone through all the steps, try testing your work in Quickplay or Practice mode to see if you've gotten the calibration right. If it's still not perfect, try calibrating again.

If you're still having trouble—or if you just want more information about calibration—please visit www.rockband.com and check out the page on calibrating *Rock Band*® 3.

LEARNING TO ROCK

Choose an instrument and learn how to use it! For information on Energy and Big Rock Endings, see p. 16.

TRAINING

You're never too good to brush up on your skills.

PRACTICE

In Practice, you aren't being scored, so it's a great way to try out advanced techniques or master a song without annoying your bandmates or the crowd. Select a song, then a difficulty level. Next, select the start and end sections of the song you want to play. Then, select the speed that's most comfortable for your playing ability. These lessons are the best place to learn all the concepts behind the all-new Pro modes for each instrument.

TIP: Tough songs are easier to tackle at slower speeds!

NEW LEARN AN INSTRUMENT

It's time to go Pro. Learn how to play a real guitar, advanced drums, and a professional level keyboard. Select the instrument you would like to learn and then choose the lesson you want to try. There are Easy Lessons, Intermediate Lessons, Hard Lessons, and Expert Lessons to choose from.

NEW LEARN A SONG

Learn how to play a specific song with your Pro Guitar or Pro Keys.

NEW DRUM FREESTYLE

You may be able to beat songs on expert, but with Drum Freestyle, you can create your own drum tracks. Adjust the BPM by pressing the directional buttons → or ←, and then go to town.

GUITARIST/BASSIST

Shred on your axe or thump out some thunderous bass lines.

- ▶ Plug in your Fender™ Stratocaster™ Guitar Controller (or any other compatible guitar peripheral) and prepare to make some serious noise!



BASICS

To play guitar, hold down the fret button that corresponds with the next note that will pass through the target. As it passes, strum up or down on the strum bar to play the note.

- ▶ To keep things simple, if you see several notes of the same color in a row, you can keep the correct fret button depressed and strum only when the note passes the target.
- ▶ When playing chords, you'll need to play more than one note at the same time. Don't panic, you'll be fine. Just press down the correct fret buttons simultaneously and strum when appropriate.
- ▶ Keep an eye on the crowd meter—it tells you how much the audience is digging your performance. Play too many wrong notes and the crowd meter slips into the red. When it's completely empty, you get kicked off the stage.

WHAMMY BAR

Customize your sound during long notes by reaching for that whammy bar.

- ▶ To use the whammy bar, press it in towards the guitar. This bends the notes you're playing and gives your tone some depth.

SOLOS

This is why you first picked up a guitar—to whip out a tasty solo and grab the spotlight all for yourself.

- ▶ When you start your solo, the solo indicator appears. The solo indicator keeps track of how many notes you've landed.
- ▶ If you have a Fender™ Stratocaster™ Guitar Controller, you can use the five special fret buttons high up on the neck near the body for soloing. When pressing these buttons, you don't need to strum, so you can finger tap that solo—or just showboat like crazy.

PRO GUITARIST

Take your guitar playing to a professional level.



NOTE: Playing in Pro mode requires the right equipment. You must have your roadie hand you a Pro Guitar controller to enable Pro Guitar mode.

DRUMMER

Blow your friends' minds with tricky beats and crazy fills!

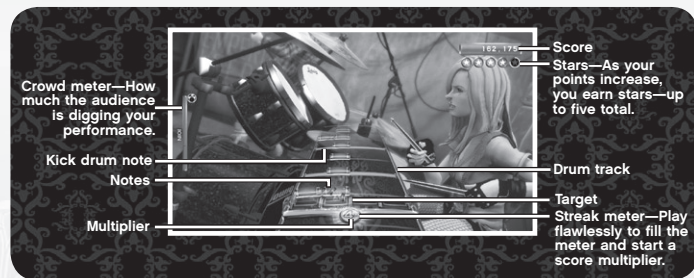

THE BASICS

Keep the beat like a human metronome by hitting the correct colored drum pad when the matching note crosses the target.

- ▶ Hit the drum pad that matches the rhythm note you see as it crosses the target at the bottom of the screen.
- ▶ The wide orange notes are for the kick pedal—stomp on that bad boy when these notes cross the target.
- ▶ Keep an eye on your crowd meter. If you miss too many notes—or hit too many of the wrong ones—you'll lose the crowd and get kicked off stage.

TIP: Before heading out onstage you might want to master the drums in the Trainers. Select TRAINING from the main menu and then select LEARN AN INSTRUMENT.

PRO DRUMMER

Think you're an expert on drums? Try Pro Drums on for size.



NOTE: In order to play Pro Drums, you will need to have at least one Rock Band Cymbal attached to your Drum Controller, although for the full rock experience, nothing beats attaching all three Rock Band Cymbals.

KEYBOARD

Show the world what a true Keyboardist can do!



PRO KEYS

Make sweet music on Pro Keys using all 15 keys.



SINGERS

Think you're worthy of wielding the mic? Plug in your USB-compatible microphone and prove it as the vocalist. Go solo or sing in harmony with two back up singers.

NOTE: If your microphone does not have built-in control buttons, then you must also have a PlayStation®3 controller connected in order to navigate the menus and set up the game.



NOTE: You must have a microphone to sing. Any USB-compatible mic should work.

LYRICS

Sing the words as they pass the bar on the left side of the screen. Follow along with the note guides.

PITCH







The pitch indicator shows you the pitch you're singing. If a song is out of your range, you can always sing an octave higher or lower. As long as you're singing the right note, you're still on the money. If you are still having a bit of trouble hitting the right notes, you can enable the all-new Pitch Correction through the Vocal Options within the Options menu.

TIP: Watch the pitch indicator. If you don't know a song, you can try to wing it by guessing until the pitch indicator lines up with the note guide.

NOTE: You may only use Pitch Correction when one microphone is plugged in. Pitch Correction is disabled when you select HARMONIES or a second microphone is plugged in.

VOLUME CONTROL

You can control how much—or how little—you hear yourself or the original artist during a song using the buttons on your PlayStation®3 controller.

- ▶ To adjust the microphone volume for singer 1, press and hold the  button, then press the directional button /▶.
- ▶ To adjust the microphone volume for singer 2, press and hold the  button, then press the directional button /▶.
- ▶ To adjust the microphone volume for singer 3, press and hold the  button, then press the directional button /▶.
- ▶ To adjust the vocal track volume, press and hold the **R1** button, then press the directional button /▶.

NOTE: If you see those special percussion notes scrolling on the screen, then whack the microphone against your hand in time with the notes passing through the target. Percussion notes allow you to play a little tambourine—or, ahem, cowbell—while the other musicians are doing their thing.

ENERGY

Build up your energy meter to go into Overdrive. Then you can whip the crowd into a frenzy, rack up some serious points, and even save yourself or a bandmate! (See *Saving Bandmates by Going into Overdrive* on p. 17). While your energy meter drains, the crowd goes nuts and your points skyrocket.

GUITAR/BASS

To build up your energy, nail the special glowing note phrases to fill up your energy meter.

When the meter is at least half-full, you can use your energy to go into Overdrive by tilting your guitar towards the heavens.

TIP: If you see a special long glowing note, then whammy that sucker to fill up your energy meter at an even faster rate.

DRUMS

If you see four solid color bars appear on the screen, then that's your cue to bust out an awesome drum fill. Drum fills unleash the energy in your energy meter, driving the crowd wild.

At the end of the drum fill, you'll see a green crash note appear. To use your energy, nail that green crash.

- ▶ If you choose, you can also wait to build your energy further before using it. To wait, simply don't hit the green crash cymbal at the end of the fill.

VOCALS

When you see a special glowing phrase, sing those sections as accurately as you can and you'll gain energy to fill your energy meter.

To use your energy, look for special lit-up yellow sections without note guides—called Freestyle Sections—and just belt something out to go into Overdrive! You're the singer after all, so improvise something!

SAVING BANDMATES BY GOING INTO OVERDRIVE!

Got a bandmate who's having an off night? Go into Overdrive, get the crowd moving, and save your band's career—all at the same time.

- ▶ If a bandmate fails during a performance, then you can bet the crowd is gonna notice—it'll bring down your crowd meter. But here's the good news: you can bring them back by using your energy.
- ▶ After you bring a bandmate back, remember: it's three strikes and they're out. After three failures, your bandmate gets kicked off stage for the rest of the song. And, yes, the crowd gets mad.

COMBINING OVERDRIVE

Sure, you can use your energy to bail out one of your less-talented bandmates, but that's no fun. What's really awesome is when you and your bandmates go into Overdrive all at the same time! Not only do you work the crowd into a frothing mass of hysteria, but you also earn a band multiplier of up to 8x! The multiplier affects everyone (not just those of you in Overdrive)—now that really racks up the points!

TIP: Going into Overdrive at the same time as your bandmates can be tricky. Keep an eye out for bandmates in Overdrive and then unleash your energy!

BIG ROCK ENDINGS

At the end of some songs, you'll have the opportunity for a Big Rock Ending. Shred on guitar or bass, or bang away on the drums like there's no tomorrow!

- ▶ If you're playing as a band, then Big Rock Endings occur for all instruments.
- ▶ If you play a big rock ending, then you'll get a major score bonus—but only if you land those last notes.
- ▶ Not all songs have Big Rock Endings—so take advantage of the ones that do!

PERSONAL MENU

Think of your menu as a dutiful roadie; always ready to work for you on a second's notice. Each player gets his or her own personal menu that can be accessed at anytime by pressing the **START** button. This menu allows players to easily drop in or out of gameplay on the fly and can also be used to customize settings during gameplay.

QUICKPLAY

Wanna just get onstage without a lot of hassle? Quickplay is your fastest way to get in front of an audience and show 'em what you've got. Band members can join at anytime by pressing the **START** button.

CHOOSE SONGS

From the Quickplay menu, select CHOOSE SONGS to select any of your *Rock Band*® 3 songs, or exported songs from other *Rock Band* titles. Play solo or with up to six other band members.

NOTE: If a band member needs to jet mid-gig, they can press the **START** button to open and select DROP OUT. You can still finish the song without them.

PLAY A SETLIST

From the Quickplay menu, select PLAY A SETLIST to create a setlist with multiple songs for a serious marathon. Play solo or with up to six other band members. To create a setlist, select MAKE A SETLIST and then add your favorite tunes. To find only the exact songs you are looking for press the **SELECT** button to change your view settings and apply filters to your song list.

CREATE A SETLIST

Create the ultimate setlist to carry the crowd through an experience they'll never forget. After selecting the perfect lineup of songs, you are able to save your playlist locally or share it with your friends. You can even convert your setlist into a Battle, which lets you and your friends compete on a limited-time leaderboard for the best score on the instrument of your choosing.

FIND ONLINE PLAYERS

Select PLAY ONLINE from the Quickplay menu. All band members must have PlayStation®Network accounts in order to join. In the Online lobby, you can invite friends to join your band or wait for other online players to be paired with you.

To invite friends to your band, press the **START** button to open your personal menu, then select PlayStation®Network OPTIONS and then INVITE FRIENDS.

If people are taking too long to hop on the band wagon, press the **X** button to play with your current lineup. Once the band is set, select a song, setlist, or party shuffle, and then choose your difficulty level.

NEW ROAD CHALLENGE

STARTING YOUR ROAD CHALLENGE

To start a Road Challenge, select START A ROAD CHALLENGE in the Play Now menu. Then you have two options, CHOOSE A ROAD CHALLENGE and FIND ONLINE PLAYERS. If you already have a band to play with, then go for the first option. If you are looking to recruit some players, select the second option.

The Choose a Road Challenge menu is like your band's bulletin board. Here, you can find the latest and greatest road trips. You can only afford local transit at first, but as you gain more fans by winning their hearts, you unlock more desirable transportation.

To see how close you are to the next vehicle, check out the profile info at the top right of the screen. There, you can see your PSN ID, how many fans you have, your current rank, and how close you are to a transit upgrade.

Each Road Challenge has a certain number of stops. You have to complete each stop in order to finish the challenge. Every gig has a certain bonus challenge. If you complete the bonus request, you earn extra love from the fans.

NEW SPADES METER

In order to reach ultimate stardom, you need to win over the audience by earning Spades. To gain Spades, complete the game's various goals. You can check out the goals you have already completed in Career.

In Road Challenge, you earn Spades by completing songs and performing special bonuses, such as using Overdrive or hitting a long streak. These bonus Spades help you unlock new content for your customized characters as well as new vehicles to travel in. The better the vehicle, the more venues you can reach.

CAREER

Visit the Career menu to see the progress you've made. Every song you play in every mode contributes to your Career progression. View rankings, song progress, and see the goals you've accomplished.

My Goals

View the goals you've accomplished or check out the long list of targets you still have yet to hit. How close are you to becoming a legend?

My Song Progress

Access the My Song Progress menu to see how many stars you've collected for each song on each difficulty.

My Rankings

Visit the My Rankings menu to see how you line up.

CUSTOMIZE

Enter the Customize menu to give your band a complete makeover. Swapping your band logo or changing your character's clothing, hair, tattoos, and instruments are just a few of the things you can customize to make your band stand out.

CUSTOMIZE BAND

Visit the Customize Band menu to edit your band's details.

Edit Band Name Throw some random nouns and adjectives into a hat and see what you can come up with. Use this menu to give your band a name that will echo throughout eternity!

Edit Band Logo Create the logo that will be proudly patched onto backpacks and stuck onto countless car bumpers.

Assign Stand-ins Whether they're off pursuing their solo career or just running late, sometimes your bandmates won't make it to the show. When that happens, fill their spots with experienced stand-ins. Use the Assign Stand-ins menu to pick your favorite musicians.

See Band History Relive your past glories by accessing the See Band History menu and viewing your band's milestones.

CUSTOMIZE CHARACTER

You can't head out onto the stage looking like chumps. Head straight to the Customize Character menu to make sure that you and your bandmates are setting the trends in style.

Clothing Accessories Visit the Clothing menu to customize what your character wears. After throwing on the latest fashion, head to the Accessories menu to add on everything from Hats to Rings.

Hair and Makeup Tattoos Instruments Access the Hair and Makeup menu to add flavor to your moneymaker. Head to the Tattoos menu to get some custom ink. Customize your instruments through this menu to make sure that you've got the greatest equipment.

CREATE CHARACTER

Not satisfied with your current bandmates? Kick them out and create some new ones.

- Name** No, you don't have to use your real name.
- Gender** Girl or boy? It's up to you.
- Outfit** Select the genre you want your rocker to represent. You can further customize his or her looks across all genres through the Customize Character menu.
- Modify Head** Time to get creative; their head is putty and you are Michelangelo. Sculpt your rockers facial features to your liking.
- Modify Body** Adjust the Height, Weight, Muscle Tone, and Skin Tone of your character through this menu.

PLAY ONLINE

ONLINE, NETWORK, CONNECTED AND/OR INTERNET PLAY, FUNCTIONALITY, FEATURES AND SUPPORT FOR ROCK BAND, ROCK BAND 2, ROCK BAND 3, ROCK BAND NETWORK AND ANY AND ALL OTHER PRODUCTS OR SERVICES OF HARMONIX MUSIC SYSTEMS, MTY NETWORKS, ELECTRONIC ARTS AND ANY THIRD PARTIES (COLLECTIVELY, "ONLINE SERVICES") ARE PROVIDED SOLELY ON AN "AS IS" AND "AS AVAILABLE" BASIS AND MAY BE MODIFIED OR DISCONTINUED WITHOUT NOTICE AT ANY TIME AND AT THE SOLE DISCRETION OF THE PARTIES, WITHOUT ANY LEGAL, FINANCIAL OR OTHER LIABILITY WHATSOEVER. NO WARRANTY, EITHER EXPRESS OR IMPLIED, IS MADE REGARDING THE ONLINE SERVICES AND UNDER NO CIRCUMSTANCES SHALL ANY REFUNDS, REBATES OR OTHER SUMS BE OWED AND/OR RETURNED IN CONNECTION WITH THE MODIFICATION, DISCONTINUATION, OR UNAVAILABILITY OF THE ONLINE SERVICES.

A PlayStation®Network account is required to play Rock Band® 3 online. You can set up a PlayStation®Network account in the System Software that appears when your PS3™ system is turned on without a disc inserted.

PLAYING ONLINE

In order to play *Rock Band® 3* online, you must create a PlayStation®Network account by following the on-screen instructions. If you already have a PlayStation®Network account, you are able to access online features automatically.

PLAYING BEHIND A FIREWALL OR ROUTER

This game uses the following network ports for playing online. If you are running a firewall, ensure it is set to allow the game to communicate on these ports both inbound and outbound:

TCP Ports: 80, 443, 5223

UDP Ports: 3478, 3479, 3658

If you are having difficulty connecting to other players online and your Internet connection is behind a router using NAT (Network Address Translation), you may need to enable port forwarding on your router by forwarding all data on port UDP 3658 to the IP address of your PlayStation®3 system. Alternatively, you can add the IP address of your PlayStation®3 system into the DMZ section of your router—please consult your router help files for details on how to do this. For more information on firewalls, port forwarding, and DMZs, please visit our online Support Center at: <http://support.ea.com>.

ROCK BAND MUSIC STORE

To access the Rock Band Music Store, select GET MORE SONGS from the main menu. Here, you can select from several categories of songs, including Newest Songs, Highest Rated Songs, Recommended songs, Friends' Favorites, RBN Highlights, and Rock Band Pro songs. You can also browse the full list of 1000+ songs available for purchase within the Store.

DISC EXPORT

Visit www.rockband.com/support for information about exporting songs from other Rock Band titles into *Rock Band® 3*!

ROCK BAND 3

Featuring music from some of the world's best bands...

RAMONES



www.ramones.com

LYNYRD
SKYNYRD

www.lynyrdskynyrd.com

OZZY
OSBURN

www.ozzy.com



www.thewho.com

DEF LEPPARD

www.defleppard.com

Slipknot

www.slipknot1.com

P H O E N I X

www.wearephoenix.com

THEM
CROOKED
VULTURES

www.themcrookedvultures.com

QUEEN

www.queenonline.com

Jim Hendrix

www.jimihendrix.com

CREDITS SONGS

REHAB

as performed by Amy Winehouse
courtesy of Mercury Records Limited under license from Universal Music Enterprises
Written by Amy Winehouse
Published by EMI Blackwood Music Inc. (BMI)

CAUGHT IN A MOSH

as performed by Anthrax
courtesy of The Island Def Jam Music Group under license from Universal Music Enterprises
Written by Joseph Bellardini, Frank Bello, Charlie Benante, Scott Rosenfeld and Daniel Spitz
Published by NFP Music (ASCAP), Universal Music - Z Tunes LLC. (ASCAP)

ONE ARMED SCISSOR

as performed by At the Drive-In
courtesy of Fearless Records
Written by Tony Hajjar, Omar Rodriguez, Cedric Bixler, Pabie Hinojos, and Jim Ward
Published by EMI April Music Inc. (ASCAP) and EMI Foray Music (SESAC)

BEAST AND THE HARLOT

as performed by Avenged Sevenfold
courtesy of Warner Bros. Records. By arrangement with Warner Music Group Video Game Licensing
Written by Zachary Baker, James Sullivan, Brian Haner Jr. and Matthew Sanders
Published by EMI APRIL MUSIC INC. (ASCAP)

ROCK LOBSTER

as performed by The B-52s
courtesy of Island Records, Inc. under license from Universal Music Enterprises. Courtesy of Warner Bros. Records Inc. By arrangement with Warner Music Group Videogame Licensing
Written by Ricky Wilson, Cynthia Wilson, Keith Strickland, Fred Schneider and Kate Pierson
Published by EMI April Music Inc. (ASCAP) and EMI Blackwood Music Inc. (BMI), Distilled Music

GOOD VIBRATIONS (LIVE)

as performed by The Beach Boys
courtesy of Capitol Records. Under license from EMI Film & Television Music
Written by Mike Love and Brian Wilson
Published by Irving Music, Inc. (BMI)

IN A BIG COUNTRY

as performed by Big Country
courtesy of Mercury Records Limited under license from Universal Music Enterprises
Written by Stuart Adlamson, Mark Brzezicki, Tony Butler and Bruce Watson
Published by EMI Virgin Music, Inc. (ASCAP)

HEART OF GLASS

as performed by Blondie
courtesy of Capitol Records. Under license from EMI Film & Television Music
Written by Debbie Harry and Chris Stein
© 1978 Chrysalis Music on behalf of itself and Monster Island Music Publishing Corp. (ASCAP)

GET UP STAND UP

as performed by Bob Marley & The Wailers
courtesy of Universal-Island Records Ltd. under license from Universal Music Enterprises
Written by Bob Marley and Peter Tosh
Published by Fifty-Six Hope Road Music Ltd., Odnih Music Ltd., State One Music America LLC, Embassy Music Corporation (BMI), Chrysalis One Songs, (BMI), Blue Mountain Music, Ltd. / Irish Town Songs (ASCAP)

FALSE ARMA

as performed by The Bronx
courtesy of Wichita Recordings
Written by Matt Caughthran, Joby Ford, James Tweedy, and Jorma Vik
Published by Universal Music - Z Tunes LLC. (ASCAP), Elvis The Other White Meat (ASCAP)

95 OR 6 TO 4

as performed by Chicago
 courtesy of Rhino Entertainment / Chicago Music. By arrangement with Warner Music Group Video Game Licensing
 Written by Robert Lamm
 Published by Warner/Chappell Music, Inc., Laminations Music (ASCAP), J W Guercio Aurelia Music (ASCAP) All rights on behalf of Laminations Music administered by WB Music Corp.

JUST LIKE HEAVEN

as performed by The Cure
 courtesy of Elektra Entertainment Group. By arrangement with Warner Music Group Video Game Licensing. Courtesy of Fiction Records/ Polydor limited under license from Universal Music Enterprises
 Written by Simon Gallup, Robert Smith, Porl Thompson, Laurence Tolhurst, and Boris Williams
 Published by Fiction Songs Ltd., Universal - MGB Songs (ASCAP)

SPACE ODDITY

as performed by David Bowie
 courtesy of RZO Music
 Written by David Bowie
 Published by TRO - Essex Music International, Inc. (ASCAP)

SMOKE ON THE WATER

as performed by Deep Purple
 courtesy of Warner Bros. Records. By arrangement with Warner Music Group Video Game Licensing. Licensed courtesy of EMI Records Ltd.
 Written by Ritchie Blackmore, Ian Gillan, Roger Glover, Jon Lord and Ian Paice
 Published by Glenwood Music Corp. (ASCAP)

FOOLIN

as performed by Def Leppard
 courtesy of Universal International Music, B.V. under license from Universal Music Enterprises
 Written by Robert Lange, Stephen Clark, and Joseph Elliott, Richard Allen, Rick Savage and Peter Willis
 Published by Out-Of-Pocket-Prod. Ltd., Universal Polygram Int. Publ., Inc. (ASCAP), Primary Wave Def Lepp (ASCAP)

WHIP IT

as performed by Devo
 courtesy of Devo
 Written by Gerald Casale and Mark Mothersbaugh
 Published by EMI Virgin Songs, Inc. (BMI)

RAINBOW IN THE DARK

as performed by Dio
 courtesy of Warner Bros. Records. By arrangement with Warner Music Group Video Game Licensing
 Written by Vinny Appice, Jimmy Bain, Vivian Campbell and Ronnie James Dio
 Published by AppiceMusic, Niji Music

WALK OF LIFE

as performed by The Dire Straits
 courtesy of Warner Bros. Records. By arrangement with Warner Music Group Video Game Licensing
 Written by Mark Knopfler
 Published by Strailjacket Songs Ltd., Almo Music Corp. (ASCAP)

CHINA GROVE

as performed by The Doobie Brothers
 courtesy of Warner Bros. Records. By arrangement with Warner Music Group Video Game Licensing
 Written by Tom Johnston
 Published by Warner/Chappell Music, Inc., Warner-Tamerlane Publishing Corp. (BMI)

BREAK ON THROUGH (TO THE OTHER SIDE)

as performed by The Doors
 courtesy of Elektra Entertainment Group. By arrangement with Warner Music Group Video Game Licensing
 Written by The Doors
 Published by Doors Music Company

KING GEORGE

as performed by Dover
 courtesy of EMI Music Spain, SA
 Written by Cristina Llanos and Amparo Llanos
 Published by Pizza Pop S.L. (SGAE), Warner/Chappell Music Spain, S.A. (SGAE), WB Music Corp.

THE KILLING MOON

as performed by Echo and The Bunnymen
 courtesy of Warner Music UK. By arrangement with Warner Music Group Video Game Licensing
 Written by Ian McCulloch, Leslie Thomas Pattinson, Peter Louis Vincent de Freitas, and William Seargant
 Published by Warner/Chappell Music, Inc., Zoo Music Ltd., WB Music Corp.

SATURDAY NIGHT'S ALRIGHT FOR FIGHTING

as performed by Elton John
 courtesy of Mercury Records Limited under license from Universal Music Enterprises
 Written by Elton John and Bernie Taupin
 Published by Dick James Music Ltd., Universal - Songs of Polygram Int., Inc. (BMI)

MIDLIFE CRISIS

as performed by Faith No More
 courtesy of London - Sire Records Ltd. By arrangement with Warner Music Group Video Game Licensing
 Written by Bill Gould, Michael Bordin, Roddy Bottum, Michael Patton and James Martin
 Published by Big Thrilling/Vomit God Music (ASCAP)

HEY MAN NICE SHOT

as performed by Filter
 courtesy of Warner Bros. Records Inc., Reprise Records. By arrangement with Warner Music Group Video Game Licensing
 Written by Richard Patrick
 Published by EMI Blackwood Music Inc. (BMI)

YOSHIMI BATTLES THE PINK ROBOTS PT. 1

as performed by The Flaming Lips
 courtesy of Warner Bros. Records Inc. By arrangement with Warner Music Group Video Game Licensing
 Written by Dave Fridmann, Wayne Coyne, Steven Drozd, and Michael Ivins
 Published by EMI Blackwood Music Inc. (BMI)

COLD AS ICE

as performed by Foreigner
 courtesy of Atlantic Recording Corp. By arrangement with Warner Music Group Video Game Licensing
 Written by Mick Jones and Louis Grammatico
 Published by Somerset Songs Publishing, Inc.

RADAR LOVE

as performed by Golden Earring
 courtesy of Geffen Records under license from Universal Music Enterprises
 Written by Barry Hay and George Kooymans
 Published by Sony/ATV Tunes LLC (ASCAP) o/b/o Snarmyook/Sony/ATV Music Publishing Holland (BUMA)

KILLING LONELINESS

as performed by H.I.M.
 courtesy of Warner Bros. Records, Sire Records. By arrangement with Warner Music Group Video Game Licensing
 Written by Ville Valo
 Published by EMI Blackwood Music Inc. (BMI)

POWER OF LOVE

as performed by Huey Lewis and The News
 courtesy of Capitol Records. Under license from EMI Film & Television Music
 Written by Johnny Colla, Chris Hayes, and Huey Lewis
 Published by Warner/Chappell Music, Inc., WB Music Corp. (ASCAP), Huey Lewis Music (ASCAP), Kinda Blue Music (ASCAP), Cause And Effect Music (ASCAP)

VIVA LA RESISTANCE

as performed by Hypemova
 courtesy of Narnack Records by arrangement with The Orchard
 Written by Ramin Seyed Emami
 Published by Narnack (BMI)

OH MY GOD

as performed by Ida Maria
 courtesy of The Island Def Jam Music Group under license from Universal Music Enterprises
 Written by Ida Sivertsen
 Published by EMI Blackwood Music Inc. (BMI)

NEED YOU TONIGHT

as performed by INXS
 courtesy of Atlantic Recording Company. By arrangement with Warner Music Group Video Game Licensing. courtesy of Warner/Chappell Music
 Written by Andrew Farriss and Michael Hutchence
 Published by Warner/Chappell Music, Inc., Chardonnay Investments LTD. (APRA) & XL Publishing Pty LTD. (APRA), WB Music Corp. (ASCAP)

CENTERFOLD

as performed by J. Geils Band
 courtesy of Capitol Records. Under license from EMI Film & Television Music
 Written by Seth Justman
 Published by Pal-Park Music (ASCAP), Almo Music Corp. (ASCAP)

I GOT YOU (I FEEL GOOD)

as performed by JAMES BROWN
courtesy of Universal Records under license from Universal Music Enterprises
Written by James Brown
Published by Fort Knox Music, Inc.

BEEN CAUGHT STEALING

as performed by Jane's Addiction
courtesy of Warner Bros. Records Inc. By arrangement with Warner Music Group Video Game Licensing
Written by Eric Avery, Perry Farrell, David Navarro and Stephen Perkins
Published by Orange Bubbly Stuff Music, Embryotic Music (BMI), I'll Hit You Back Music (BMI), Swizzlestick Music (BMI), Irving Music, Inc. (BMI)

CROSTOWN TRAFFIC

as performed by Jimi Hendrix
courtesy of Experience Hendrix LLC/MCA Records under license from Universal Music Enterprises
Written by Jimi Hendrix
Published by Experience Hendrix, L.L.C.

I LOVE ROCK N ROLL

as performed by Joan Jett and The Blackhearts
courtesy of Blackheart Records Group
Written by Alan Merrill and Jake Hooker
Published by Finchley Music Corporation

IMAGINE

as performed by John Lennon
courtesy of Capitol Records. Under license from EMI Film & Television Music
Written by John Lennon
Published by EMI Blackwood Music, Inc. (BMI)

ME ENAMORA

as performed by Juanes
courtesy of Universal Music Latino under license from Universal Music Enterprises
Written by Juan Esteban Aristizabal
Published by Peermusic III Ltd. (BMI), Songs of Camaleon (BMI)

FREEBIRD (LIVE)

as performed by Lynrd Skynyrd
courtesy of Geffen Records under license from Universal Music Enterprises
Written by Allen Collins and Ronnie Van Zant
Published by Songs of Universal, Inc. (BMI), Longitude Music (BMI)

OYE MI AMOR

as performed by Mana
courtesy of Warner Music Mexico/Warner Music Latina. By arrangement with Warner Music Group Video Game Licensing
Written by Rher Olvera and Alex Gonzalez
Published by Tulum Music (ASCAP), Big Cojones Music (ASCAP).
WB Music Corp.

THE BEAUTIFUL PEOPLE

as performed by Marilyn Manson
courtesy of Interscope Records under license from Universal Music Enterprises
Written by Brian Warner and Jeordie White
Published by Dinger and Ollie Music (BMI)/Blood Heavy Music (BMI)/Songs of Golgotha (BMI), HoriPro Entertainment Group, Inc.

COMBAT BABY

as performed by Metric
courtesy of Everloving Records / Rhino Independent. By arrangement with Warner Music Group Video Game Licensing
Written by Emily Haines and James Shaw
Published by Chrysalis Music (ASCAP)

OUTER SPACE

as performed by the Muffs
courtesy of the Muffs
Written by Kimberly Shattuck
Published by Circus Sized Peanuts (ASCAP) c/o The Bicycle Music Company

SISTER CHRISTIAN

as performed by Night Ranger
courtesy of Geffen Records under license from Universal Music Enterprises
Written by Kelly Keagy
Published by Figs. D Music (BMI) & Rough Play Music (BMI) c/o The Bicycle Music Company

CRAZY TRAIN

as performed by Ozzy Osbourne
courtesy of Epic Records
Written by Osbourne, Rhoads and Daisley
Published by Blizzard Music Limited

MISERY BUSINESS

as performed by Paramore
courtesy of Atlantic Recording Corp. / Fueled By Ramen. By arrangement with Warner Music Group Video Game Licensing
Written by Josh Farro and Hayley Williams
Published by Warner/Chappell Music, Inc., WB Music Corp. (ASCAP), But Father, I Just Want To Sing Music (ASCAP), FBR Music (ASCAP), Josh's Music (ASCAP)

LLAMA

as performed by Phish
courtesy of Elektra Entertainment. By arrangement with Warner Music Group Video Game Licensing
Written by Trey Anastasio
© Who Is She? Music, Inc. (BMI)

LISSO

as performed by Phoenix
courtesy of Glassnote Records
Written by Laurent Mazzalai, Christian Mazzalai, Thomas Croquet and Frederic Moulin
Published by Ghettablaster S.A.R.L. administered by Kobalt Music Publishing America, Inc.

DON'T STAND SO CLOSE TO ME

as performed by The Police
courtesy of A&M Records, Ltd. Under license from Universal Music Enterprises
Written by Sting
Published by EMI Blackwood Music Inc. (BMI)

ANTIBODIES

as performed by Poni Hoax
courtesy of Tigersushi Records
Written by Arnaud Roulin, Frederic Souldard, Laurent Bardainne, Nicolas Langlois, Nicolas Villebrun and Vincent Taeger
Published by Sony/ATV Music Publishing o/o Sony/ATV Music Publishing France and Tigersushi (JN2B)

SOMETHING BIGGER SOMETHING

as performed by Pretty Girls Make Graves
courtesy of Matorador Records
Written by Derek Fudesco, Jason Clark, Nathan Johnson, Nicholas Dewitt and Andrea Zollo
Published by Mattitude Music LLC

JERRY WAS A RACE CAR DRIVER

as performed by Primus
courtesy of Interscope Records under license from Universal Music Enterprises
Written by Les Claypool, Reid LaLonde and Tim Alexander
Published by Sturgeon (BMI)

BOHEMIAN RHAPSODY

as performed by Queen
Licensed courtesy of Queen Productions Limited/EMI Records Ltd./Hollywood Records
Written by Freddie Mercury
Published by Glemwood Music Corp. (ASCAP)

NO ONE KNOWS

as performed by Queens of the Stone Age
courtesy of Interscope Records under license from Universal Music Enterprises
Written by Josh Homme, Mark Lanegan and Nick Oliver
Published by Warner-Tamerlane Publishing Corp. (BMI), Board Staff Music (BMI), Ripplestick Music (BMI), Natural Light Music (BMI), EMI Blackwood Music Inc. (BMI)

DU HAST

as performed by Rammstein
courtesy of Motor Music GmbH under license from Universal Music Enterprises
Written by Richard Kruspe, Heiko Landers, Till Lindemann, Christian Lorenz, Oliver Riedel, and Christoph Schneider
Published by TamTam Falik Musikverlag, Inh Emanuel Fialik, Kobalt Music Publishing America, Inc., Discoton Musik Ed. GmbH. Universal Music - MGB Songs (ASCAP)

I WANNA BE SEDATED

as performed by the Ramones
courtesy of Warner Bros. Records Inc.. Sire Records Company. By arrangement with Warner Music Group Video Game Licensing
Written by Doug Colvin, John Cummings and Jeff Hyman
Published by Warner/Chappell Music, Inc. WB Music Corp. (ASCAP)
Taco Tunes (ASCAP)

LAST DANCE

as performed by The Raveonettes
courtesy of Vice Music, Inc. by arrangement with The Orchard
Written by Sune Rose Wagner and Thomas Troelsen
Published by Juvenile Delinquent Music (ASCAP) administered by Kobalt Music Publishing America, Inc., Troelsen Publishing (ASCAP).

PORTIONS FOR FOXES

as performed by Rilo Kiley
courtesy of Warner Bros. Records
Written by Jenny Lewis and Blake Sennett
Published by Deprecious Music (BMI), Wonderful Pony Music (BMI) Big Blue Boat Music (BMI), BB Lindstrom (BMI). By arrangement with Warner Music Group Video Game Licensing

DON'T BURY ME... I'M STILL NOT DEAD

as performed by Riverboat Gamblers
courtesy of Volcom Entertainment
Written by Fadi El-Assad, Patrick Lillard, Ian MacDougall and Michael Wiebe
Published by Gambler Rich Entertainment

THE LOOK

as performed by Roxette
courtesy of EMI Music Sweden, AB
Written by Per Hakan Gessle
Published by Jimmy Fun Music, Sony/ATV Melody

BEFORE I FORGET

as performed by Slipknot
courtesy of Roadrunner Records
Written by Nathan Jordison, Corey Taylor, Paul Gray, James Root, Michael Graham, Chris Fehn, Mickael Thomson, Sid Wilson, and Craig Jones
Published by EMI April Music Inc. (ASCAP)

WALKING ON THE SUN

as performed by Smash Mouth
courtesy of Interscope Records under license from Universal Music Enterprises
Written by Gregory Camp, Paul Delisle, Steven Harwell, and Kevin Linnello
Published by Warner/Chappell Music, Inc., Warner-Tamerlane Publishing Corp. (BMI), Squish Moth Music (BMI)

STOP ME IF YOU THINK YOU'VE HEARD THIS ONE BEFORE

as performed by The Smiths
courtesy of Warner Music UK. By arrangement with Warner Music Group Video Game Licensing
Written by Johnny Marr and Steven Morrissey
Published by Warner/Chappell Music, Inc., Artemis Muziekuitgeverij B.V. (BUM/STE), Universal Music Publishing Limited (GB) (PRS), Marr Songs Ltd., Universal - PolyGram Int. Publ., Inc. (ASCAP)

LIVING IN AMERICA

as performed by The Sounds
courtesy of Warner Music Sweden. By arrangement with Warner Music Group Video Game Licensing
Written by Jesper Anderberg, Johan Bengtsson, Maja Ivarsson, Frederick Nilsson and Felix Rodriguez
Published by Chrysalis One Music (ASCAP)

IN THE MEANTIME

as performed by Spacehog
courtesy of Atlantic Recording Company, Elektra Entertainment Group. By arrangement with Warner Music Group Video Game Licensing
Written by Royston Langdon
Published by Hog Space Music

FLY LIKE AN EAGLE

as performed by Steve Miller Band
courtesy of Capitol Records. Under license from EMI Film & Television Music
Written and composed by Steve Miller
Published by Sailor Music (ASCAP)

PLUSH

as performed by Stone Temple Pilots
courtesy of Atlantic Recording Corp. By arrangement with Warner Music Group Video Game Licensing
Written by Dean DeLeo, Robert DeLeo, Eric Kretz and Scott Weiland
Published by Milksongs (ASCAP), Universal Music Corp. (ASCAP), Triple Kauf Noplate Muzak (ASCAP) administered by Bug

THIS BASTARD'S LIFE

as performed by Swingin' Utters
courtesy of Fat Wreck Chords
Written by Max Huber
(Copyright Control) In arrangement by Railer Entertainment

EVERYBODY WANTS TO RULE THE WORLD

as performed by Tears For Fears
courtesy of Mercury Records limited under license from Universal Music Enterprises
Written by Chris Hughes, Roland Orzabal and Ian Stanley
Published by EMI Virgin Songs, Inc. (BMI)

THE CON

as performed by Tegan and Sara
courtesy of Warner Bros. Records, Sire Records Company. By arrangement with Warner Music Group Video Game Licensing
Written by Tegan Quin and Sara Quin
Published by Naked In A Snowsuit Publishing (SOCAN)

DEAD END FRIENDS

as performed by Them Crooked Vultures
courtesy of Interscope Records under license from Universal Music Enterprises
Written by John Baldwin, Dave Grohl and Josh Homme
Published by Warner/Chappell Music, Inc., Cap Three LTD (PRS), Warner-Tamerlane Publishing Corp. (BMI), The Redundancy Corporation of Redundancy (BMI), MJ Twelve Music (BMI), Songs Of Universal, Inc. (BMI)

HUMANOID

as performed by Tokio Hotel
courtesy of Interscope Records under license from Universal Music Enterprises
Music by Patrick Benzner, David Jost, Dave Roth and Tom Kaulitz
Words by Patrick Benzner, David Jost, Dave Roth and Bill Kaulitz
Published by Benzner Publishing, Emma's Park Music, Jost Music Publishing, Edition Hotelbar, Kobalt Music Publishing America, Inc.

I NEED TO KNOW

as performed by Tom Petty and The Heartbreakers
courtesy of Gone Gator Records by arrangement with Wixen Music Publishing, Inc.
Written by Tom Petty
Published by Tarka Music, Almo Music Corp. (ASCAP)

20TH CENTURY BOY

as performed by T. Rex
courtesy of Spirit Music Group Inc. o/b/o Spirit Services Holdings, S.à.r.l.
Written by Marc Bolan
Published by Spirit One Music o/b/o Spirit Services Holdings, S.à.r.l.

GET FREE

as performed by The Vines
courtesy of Capitol Records. Under license from EMI Film & Television Music
Written by Craig Nicholls
Published by Mushroom Music Pty. Ltd. (APRA), Sony/ATV Tunes LLC (ASCAP), Ivy Leag, Sony/ATV Music Publishing LLC

LOW RIDER

as performed by WAR
courtesy of Avenue Records
Written by Sylvester Allen, Harold Brown, Morris Dickerson, Jerry Goldstein, Le Roy Jordan, Charles Miller, Lee Oskar and Howard Scott
Published by Far Out Music, Inc. (ASCAP), Universal - PolyGram Int. Publ., Inc. (ASCAP)

WEREWOLVES OF LONDON

as performed by Warren Zevon
courtesy of Elektra Entertainment Group. By arrangement with Warner Music Group Video Game Licensing
Written by Warren Zevon, LeRoy Marinell and Robert Wachtel
Published by Zevon Music, Tiny Tunes, Leadsheet Land Music

THE HARDEST BUTTON TO BUTTON

as performed by The White Stripes
courtesy of Third Man Records/XL Recordings
Written by Jack White III
Published by Peppermint Stripe Music

HERE I GO AGAIN

as performed by Whitesnake
courtesy of Geffen Records under license from Universal Music Enterprises
Written by David Coverdale and Bernie Marsden
Published by Warner/Chappell Music, Inc., C.C. Songs LTD. (PRS), WB Music Corp., EMI Virgin Songs, Inc. o/b/o EMI Longitude Music (BMI)

I CAN SEE FOR MILES

as performed by The Who
courtesy of Polydor Records Ltd. (U.K.) under license from Universal Music Enterprises
Written by Peter Dinklage
Published by TRO - Essex Music, Inc. (ASCAP)

ROUNDABOUT

as performed by Yes
courtesy of Atlantic Recording Company. By arrangement with Warner Music Group Video Game Licensing
Written by Jon Anderson and Steve Howe
Published by Topographic Music Ltd. (ASCAP), WB Music Corp.

SIMPLETON

as performed by The Acrobats
courtesy of Susspool Records
Written by C. Wissmuller and D. Sussmann
© 2010 The Acrobats (BMI)

HERE COME THE GUNS

as performed by Choo Choo La Rouge
courtesy of KIAM Records
Written by Vincent Scorzello, Chris Lynch, and Jon Langmead
© 2009 Choo Choo La Rouge (BMI)

EVERYTHING I HATE ABOUT MYSELF

as performed by Death of the Cool
Written by Izzy Maxwell
© 2010 Izzy Maxwell

MORE

as performed by Down June
Written by Kristin Clow Sawyer
© 2006 Down June

BLINK

as performed by Father Octopus
Written by Geoff Pitsch and Dan Brakeley
© 2008 Geoff Pitsch

SIGNS

as performed by Giant Target
Written by Aaron Price, Caleb Wheeler, Daniel Chace, and Phillip Hunt
© 2009 Giant Target

BURIED ALIVE

as performed by The Holepunch Generation
courtesy of Audiobulb Records
Written by Patrick Balthrop
© 2010 Audiobulb Records

OSPREY

as performed by LOON
Written by Anne Marie Ticaric, Paul Lyons, and Mis Zill
© 2010 LOON

TEN KINGDOMS

as performed by Megasus
courtesy of Wild Power/20 Buck Spin
Written by Ryan Lesser, Paul Lyons, Jason Kendall, and Brian Gibson
© 2008 Megasus

LOVE AND TONIC

as performed by Milquetoast & Co.
Written by James McAndrew, Robin Ryczek, Bill Whitney,
Joe Mageary, and Francis Quinn
© 2010 Milquetoast & Co. (BMI)

RIPPING THROUGH LIFE

as performed by Soul Remnants
Written by Tom Preziosi, Mitch Fletcher, and Brett Jean
© 2007 Soul Remnants

FLYTRAP

as performed by Spirit Kid
courtesy of RPL Audio
Written by Emeen Zarookian
© 2010 EZ Beats

THIS WAR WILL NEVER START

as performed by Steve Pardo
Written by Steve Pardo
© 2010 Steve Pardo (ASCAP)

WE HAVE ARRIVED

as performed by Taxpayer
Written by Taxpayer
© 2009 Bunny Foo Foo (ASCAP)

DISCO CITY

as performed by That Handsome Devil
Written by Christian Oppel and Jeremy Page
© 2009 Glum Merymaker (BMI)

TRASH CANDY

as performed by Tijuana Sweetheart
Written by Helen "The Hellion" McWilliams (BMI)
© 2009 Tijuana Sweetheart

LIMITED 90-DAY SOFTWARE WARRANTY

ELECTRONIC ARTS LIMITED WARRANTY

Electronic Arts warrants to the original purchaser of this product that the recording medium on which the software program(s) are recorded (the "Recording Medium") and the documentation that is included with this product (the "Manual") are free from defects in materials and workmanship for a period of 90 days from the date of purchase. If the Recording Medium or the Manual is found to be defective within 90 days from the date of purchase, Electronic Arts agrees to replace the Recording Medium or Manual free of charge upon receipt of the Recording Medium or Manual at its service center, postage paid, with proof of purchase. This warranty is limited to the Recording Medium containing the software program and the Manual that were originally provided by Electronic Arts. This warranty shall not be applicable and shall be void if, in the judgment of Electronic Arts, the defect has arisen through abuse, mistreatment or neglect.

This limited warranty is in lieu of all other warranties, whether oral or written, express or implied, including any warranty of merchantability or fitness for a particular purpose, and no other representation of any nature shall be binding on or obligate Electronic Arts. If any such warranties are incapable of exclusion, then such warranties applicable to this product, including implied warranties of merchantability and fitness for a particular purpose, are limited to the 90-day period described above. In no event will Electronic Arts be liable for any special, incidental, or consequential damages resulting from possession, use or malfunction of this Electronic Arts product, including damage to property, and to the extent permitted by law, damages for personal injury, even if Electronic Arts has been advised of the possibility of such damages. Some states do not limit limitation as to how long an implied warranty lasts and/or exclusions or limitation of incidental or consequential damages so the above limitations and/or exclusion of liability may not apply to you. In such jurisdictions, the Electronic Arts liability shall be limited to the fullest extent permitted by law. This warranty gives you specific rights. You may also have other rights that vary from state to state.

RETURNS WITHIN THE 90-DAY WARRANTY PERIOD

Please return the product along with (1) a copy of the original sales receipt showing the date of purchase, (2) a brief description of the difficulty you are experiencing, and (3) your name, address and phone number to the address below and Electronic Arts will mail a replacement Recording Medium and/or Manual to you. If the product was damaged through misuse or accident, this 90-day warranty is rendered void and you will need to follow the instructions for returns after the 90-day warranty period. We strongly recommend that you send your products using a traceable delivery method. Electronic Arts is not responsible for products not in its possession.

EA WARRANTY INFORMATION

If the defect in the Recording Medium or Manual resulted from abuse, mistreatment or neglect, or if the Recording Medium or Manual is found to be defective after 90 days from the date of purchase, choose one of the following options to receive our replacement instructions:

Online: <http://warranty.info.ea.com>

Automated Warranty Information: You can contact our automated phone system 24 hours a day for any and all warranty questions: US 1 (650) 698-1001

EA WARRANTY MAILING ADDRESS

Electronic Arts Customer Warranty
9001 N I-35 Suite 110
Austin, TX 78753

© 2010 Harmonix Music Systems, Inc. All rights reserved. Covered by the following U.S. Patents: 6,429,863, 6,482,087, 7,164,076, 7,459,624, 7,625,284 and patent applications pending. Harmonix, Rock Band, Rock Band 2, Rock Band 3, Rock Band Network and all related titles and logos are trademarks of Harmonix Music Systems, Inc., an MTV Networks company. Rock Band, Rock Band 2, Rock Band 3 and Rock Band Network developed by Harmonix Music Systems, Inc. MTV, MTV Games and all related titles and logos are trademarks of MTV Networks, a division of Viacom International Inc. All other trademarks are properties of their respective owners.

"PlayStation", "DUALSHOCK" and "SIXAXIS" are registered trademarks and "PS3" is a trademark of Sony Computer Entertainment Inc. The ESRB rating icons are registered trademarks of the Entertainment Software Association.